

**DTSW 0862/0863
SW 0864**

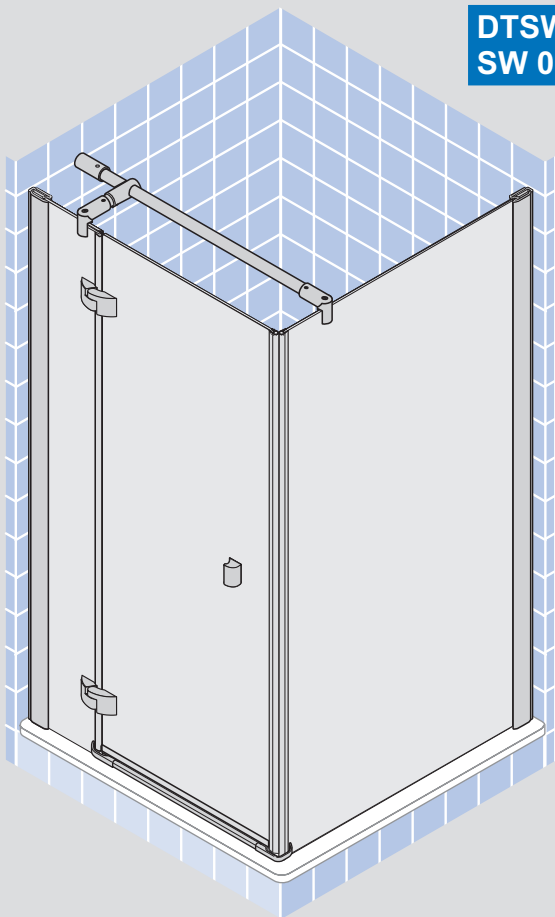

**DTSW 0862/0863
BSW 0873**

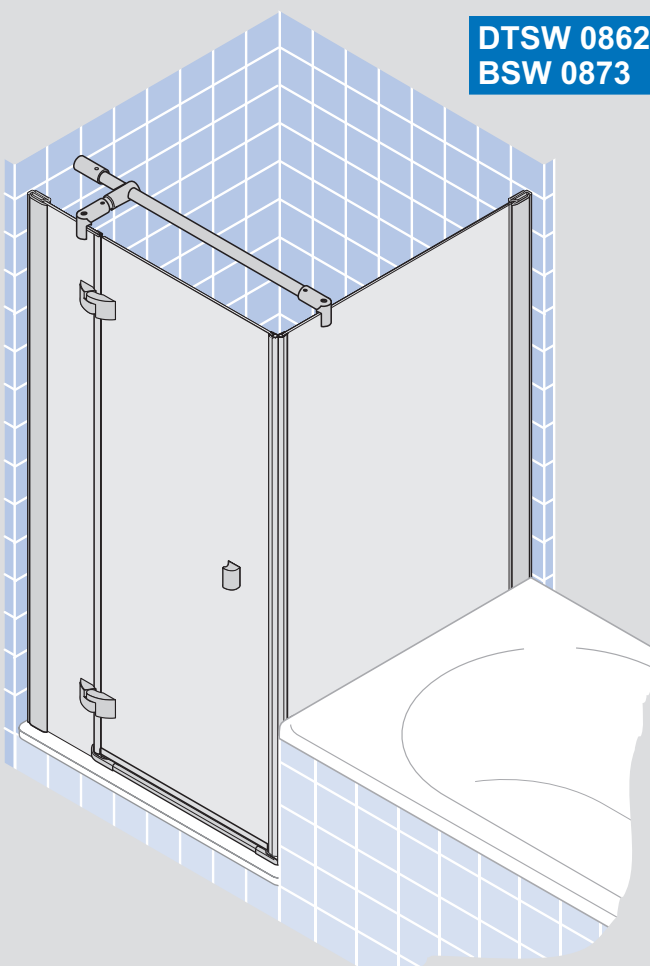

**DTSW 0862
DTSW 0863
SW 0864
BSW 0873**

D	Montageanleitung
GB	Installation instructions
F	Instructions de montage
I	Istruzioni di montaggio
E	Instrucciones de montaje
NL	Montagehandleiding
GR	Οδηγία συναρμολόγησης
RUS	Инструкция по монтажу
DK	Montagevejledning
CZ	Návod k instalaci
PL	Instrukcja montażu
S	Monteringsanvisning
P	Instrução de montagem
H	Szerelési utasítás

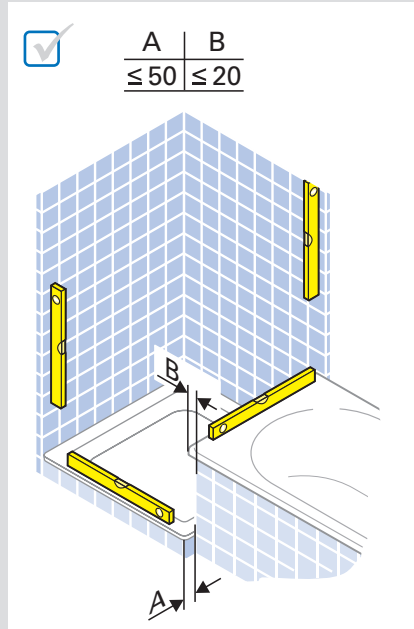
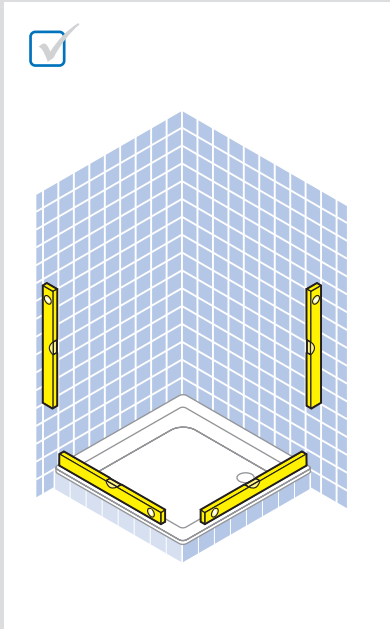
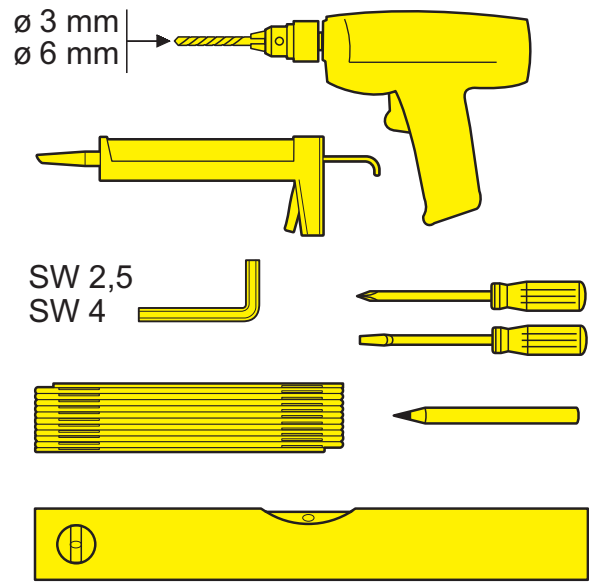
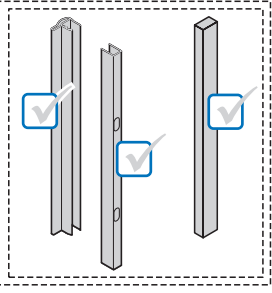
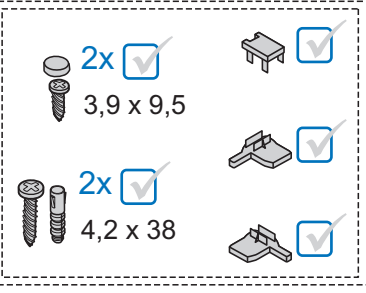
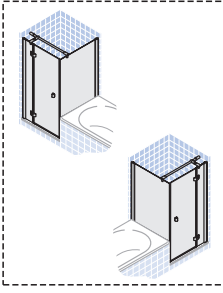
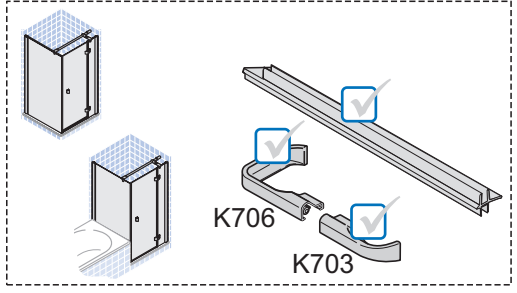
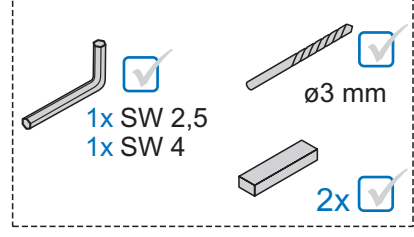
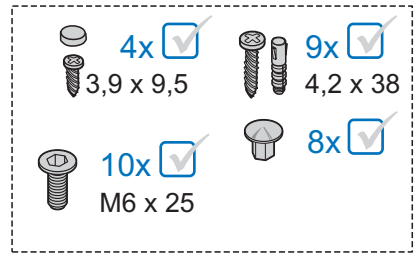
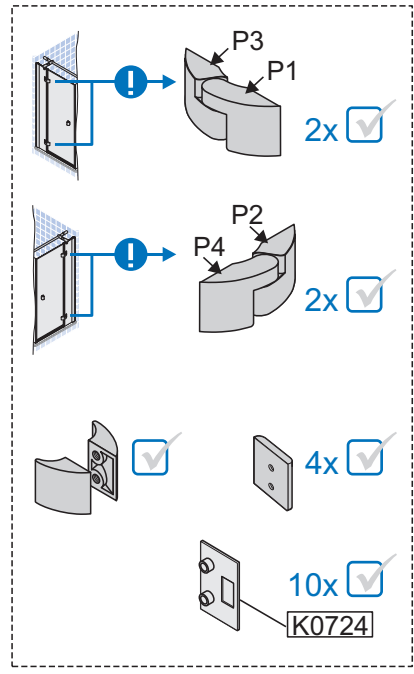
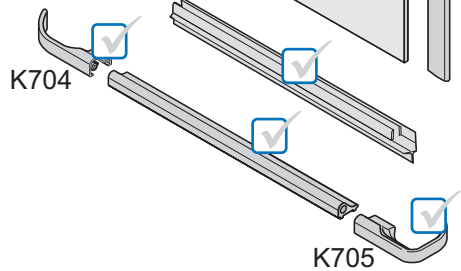
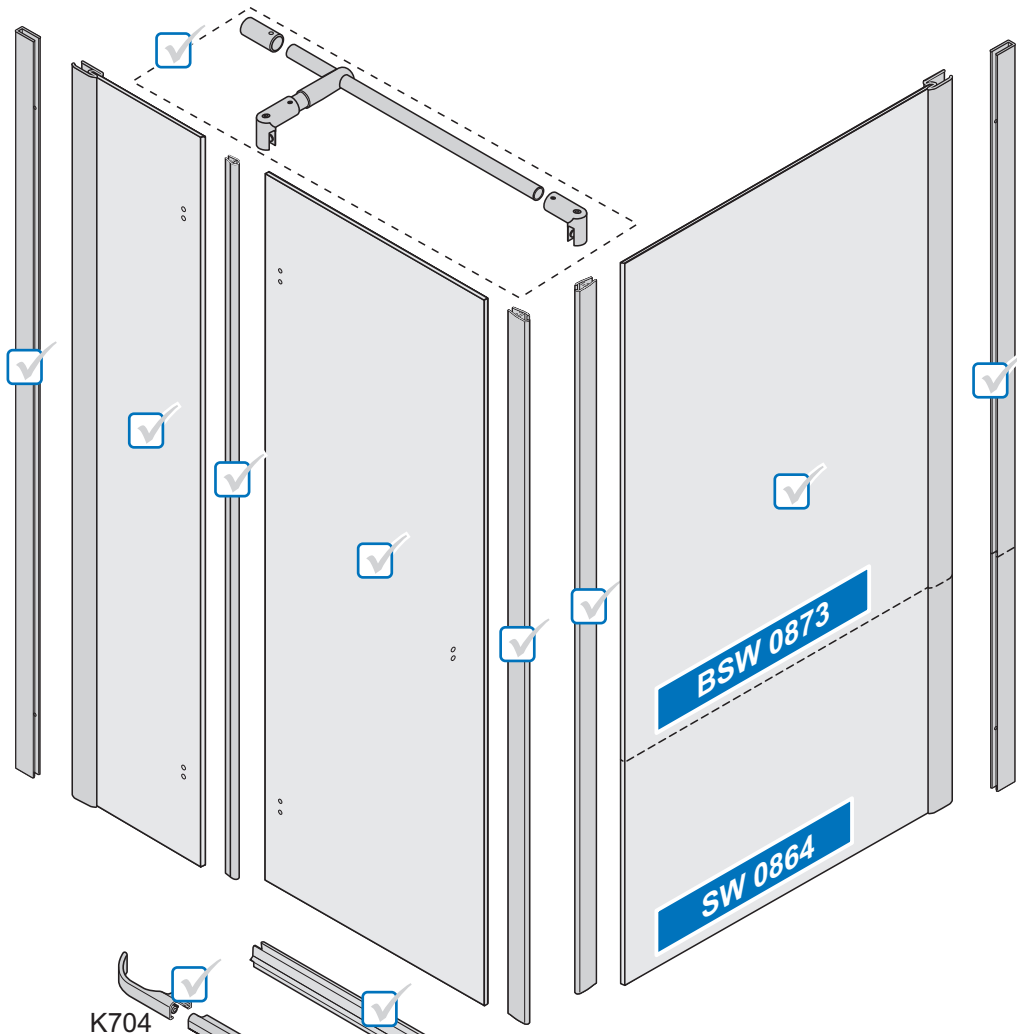

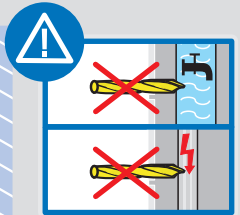
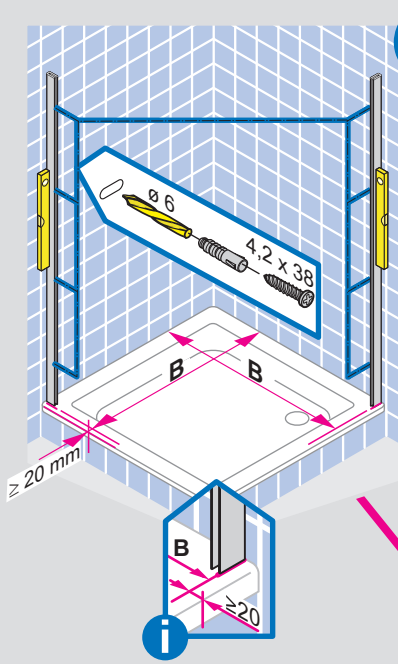
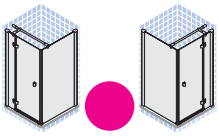

A	B
700	665-685
750	715-735
800	765-785
900	865-885
1000	965-985
1200	1165-1185
SOM	A-20

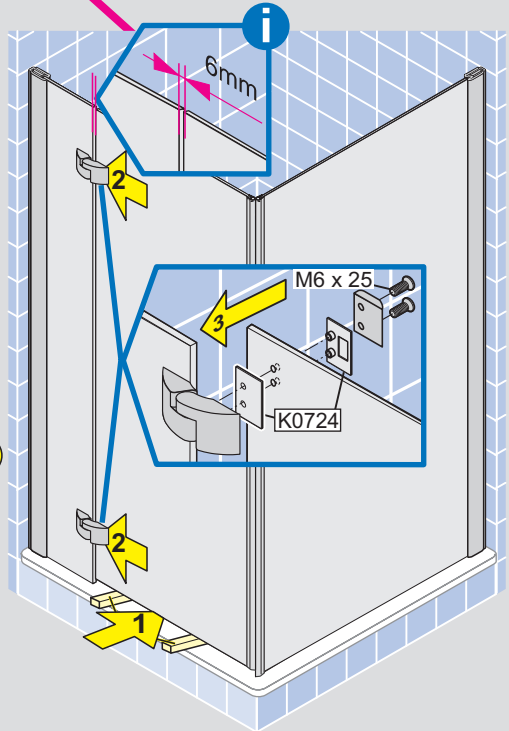
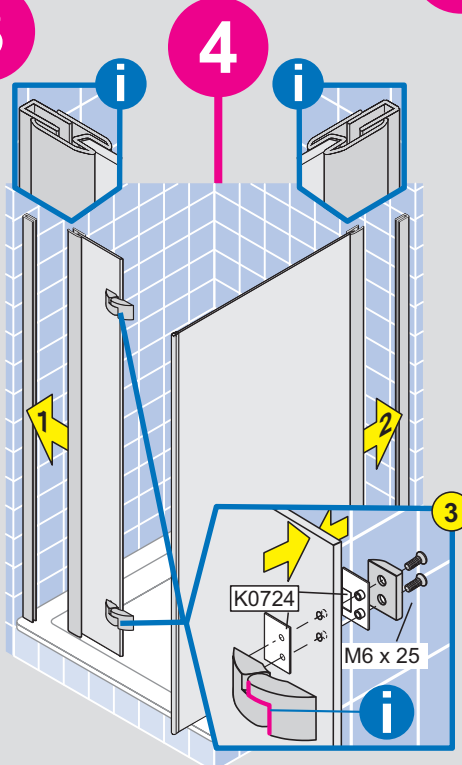
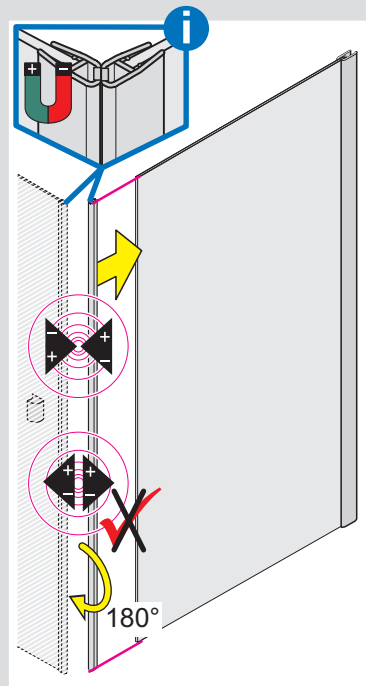
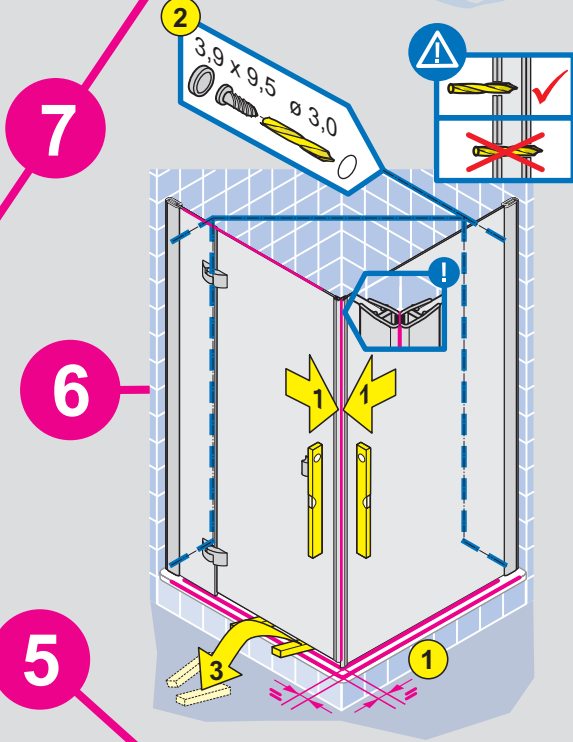
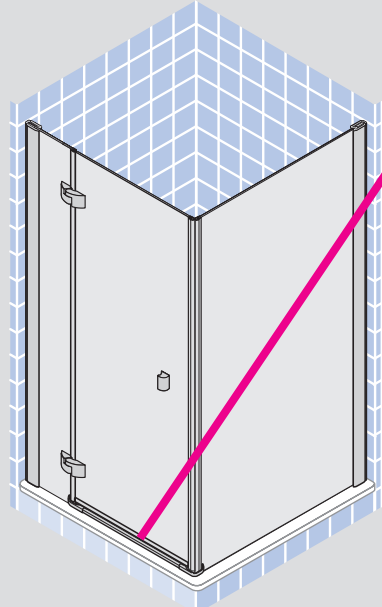
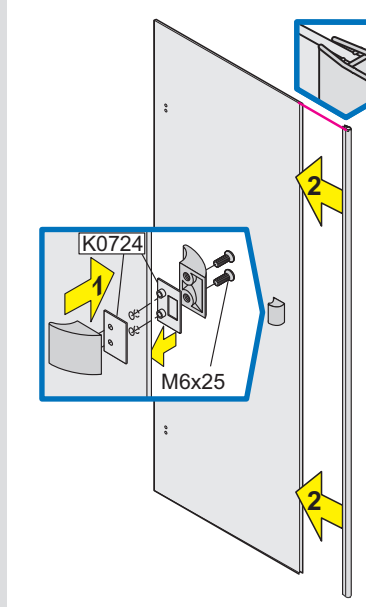
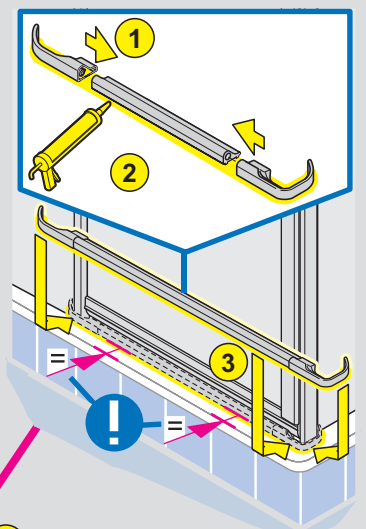

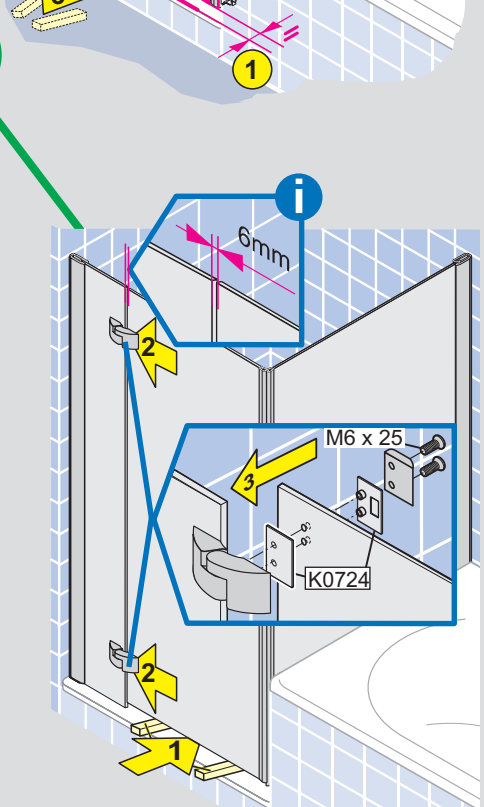
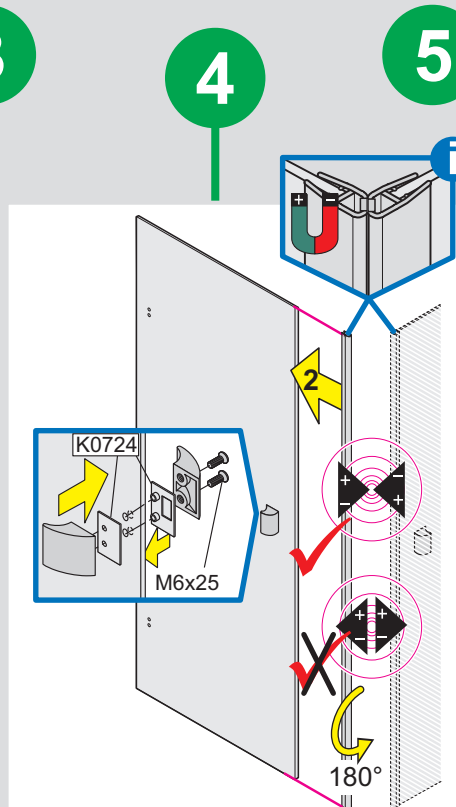
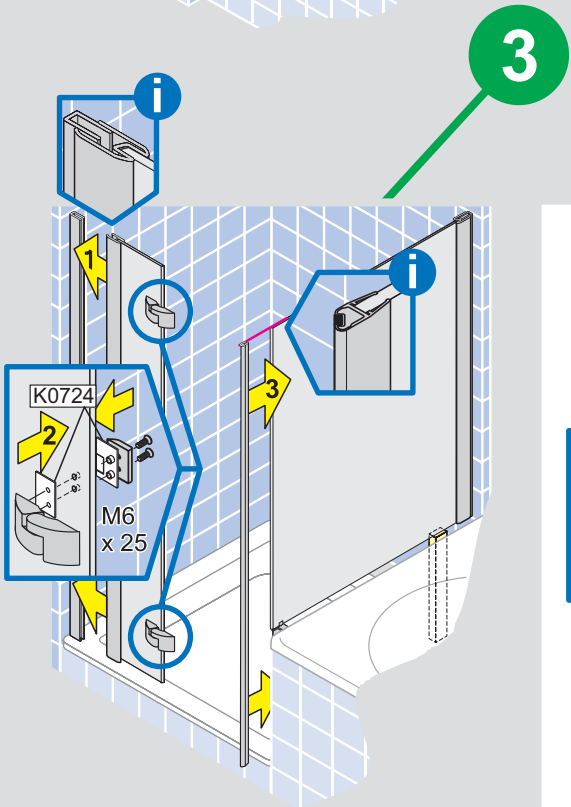
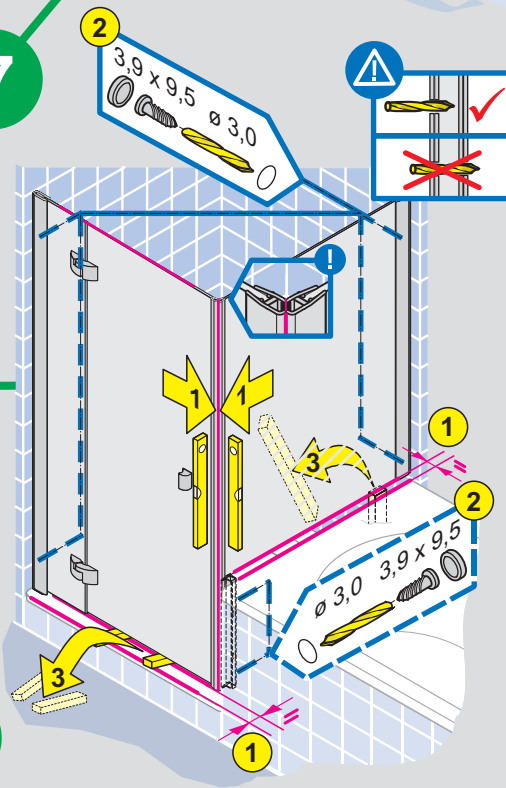
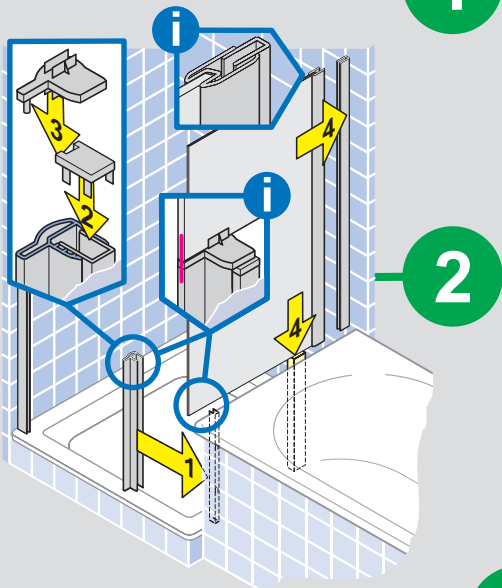
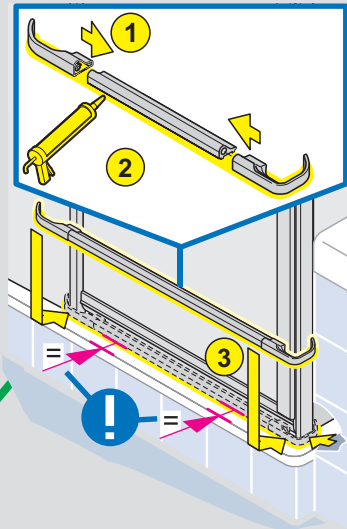
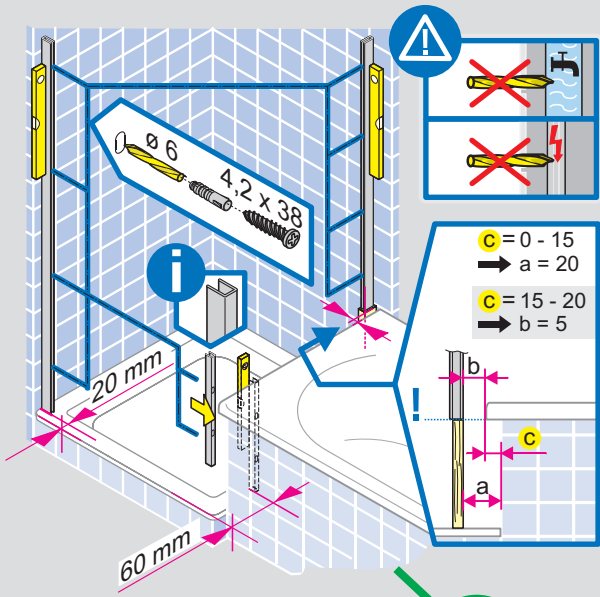
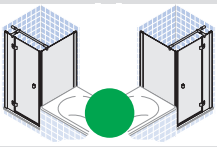

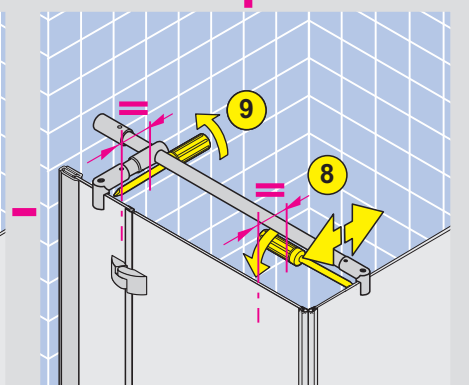
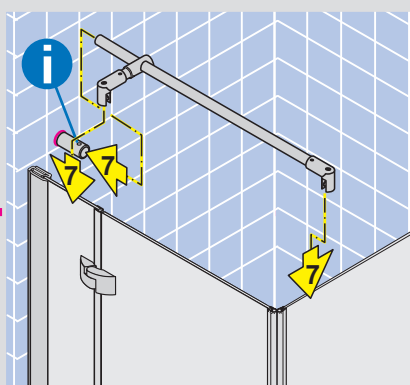
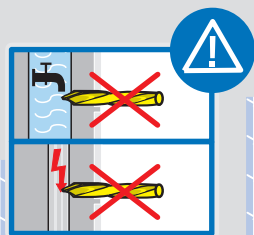
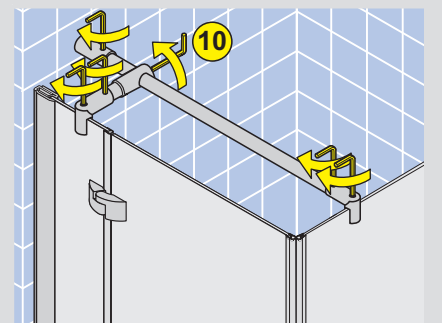
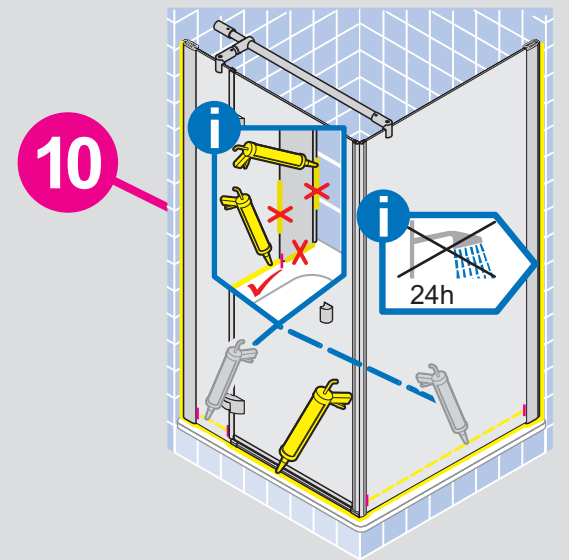
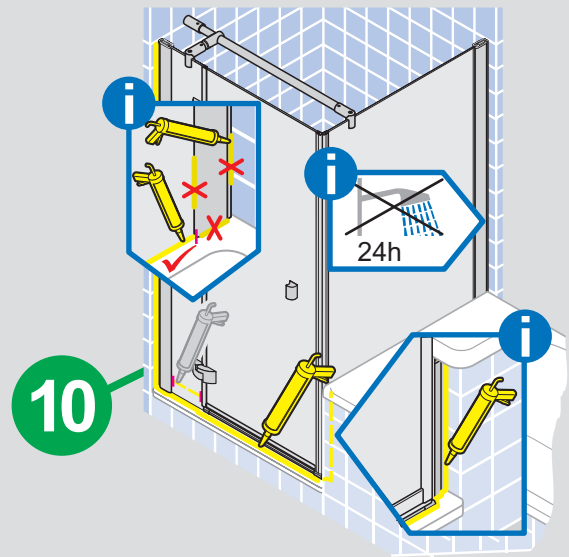
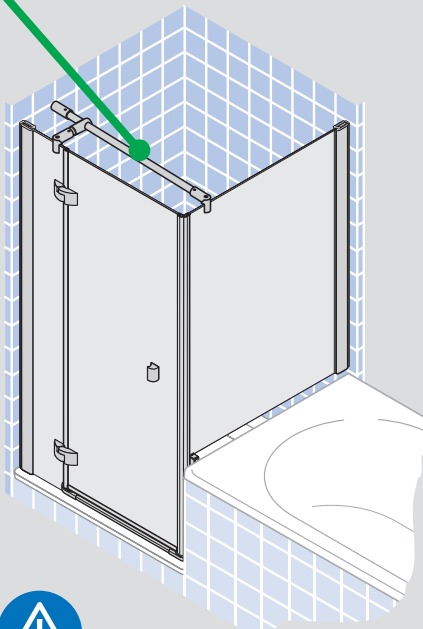
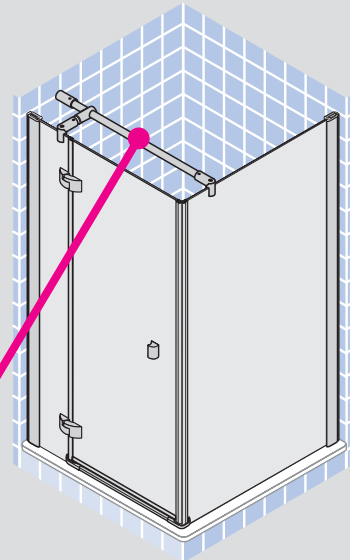
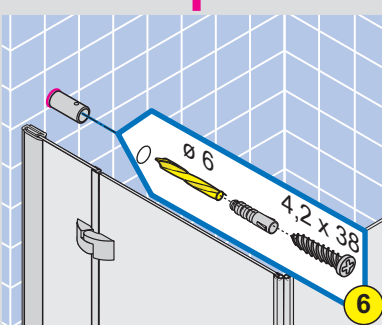
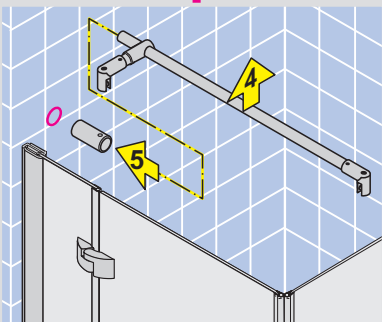
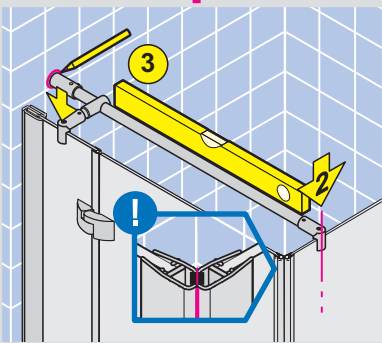
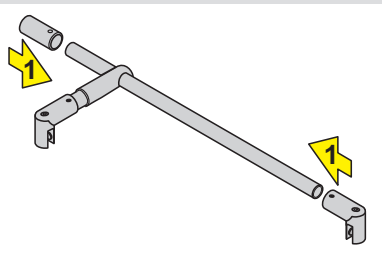
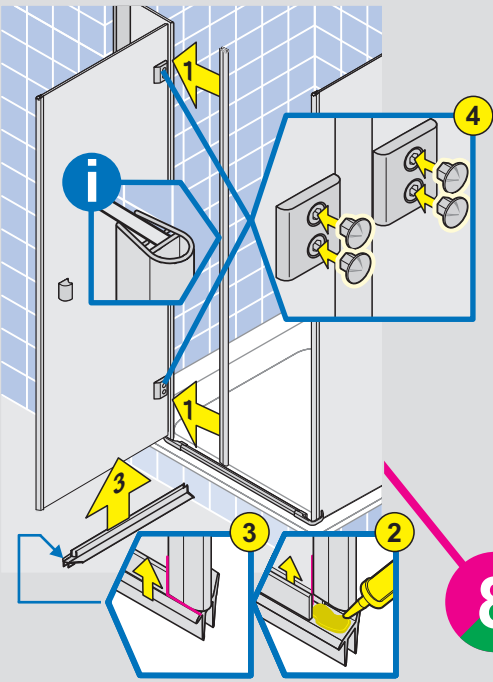
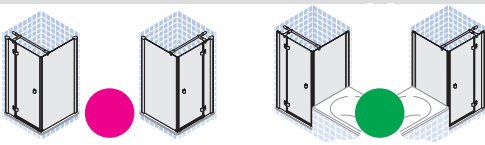

D Wichtiger Hinweis:
Duschkabinen bitte vor dem Einbau auf Transportschäden und Vollständigkeit prüfen, da Beanstandungen nach dem Aufbau nicht mehr anerkannt werden können.

GB Important information:
Please check the shower enclosure for transport damage and completeness before installation. Complaints made following installation cannot be accepted.

F Remarque importante:
avant de procéder au montage, vérifiez que le pare-douche est complet et qu'il n'a pas été endommagé lors du transport. Aucune réclamation ne pourra être admise après le montage.

I Avviso importante:
Prima di effettuare il montaggio vi preghiamo di controllare se la parete divisoria della doccia presenta dei danni di trasporto. Dopo il montaggio non vengono più accettati reclami.

E Nota importante:
Por favor, antes de montar la mampara se debe controlar que el producto no haya sufrido daños durante el transporte y que todas las piezas estén completas. Una vez instalado el artículo no asumiremos ninguna responsabilidad por las eventuales reclamaciones.

NL Belangrijk:
Controleer voor het inbouwen of het douchescherm bij het transport beschadigd is en of het volledig is. Na het inbouwen kunnen klachten niet meer in behandeling genomen worden.

GR Σημαντική υπόδειξη:
Παρακαλούμε ελέγξτε την διαχωριστική ντουζέρια πριν την συναρμολόγηση σχετικά με φθορές εκ μεταφοράς και πληρότητα. Μετά το μοντάρισμα δεν αναγνωρίζονται πλέον οι σχετικές διαμαρτυρίες.

RUS Важное указание:
Пожалуйста проверьте душевые кабины перед монтажом на повреждения в результате транспортировки и на комплектность. Рекламации после монтажа не принимаются.

DK Vigtig oplysning:
Inden kabinenæggen monteres, undersøges den for transportskader o.lign., idet reklamationer ikke kan godkendes efter at monteringen har fundet sted.

CZ Důležité upozornění:
Před instalací sprchové kabiny přezkontrolujte, prosím, zda nebyla kabina během přepravy poškozena a zda je dodávka kompletní. Po zabudování nemůže být reklamacie již uznána.

PL Ważna wskazówka:
Przed zabudowaniem prysznicowej ścianki działowej należy sprawdzić jej kompletność i skontrolować na obecność ewentualnych uszkodzeń powstałych w czasie transportu. Po dokonaniu zabudowy reklamacje nie będą uwzględniane.

S Viktig hänvisning:
Innan duschskiljeväggen byggs in måste man kontrollera att inga transportskador uppkommit på den och att den är fullständig. När den byggs in kan inte några reklamationer accepteras längre.

P Indicação importante:
Favor verificar antes da instalação se a separação de chuveiro está completa e se sofreu danos de transporte. Depois da montagem não se aceitam reclamações.

H Fontos tudnivaló:
Kérjük, beépítés előtt ellenőrizze a zuhanylevélasztót, hogy a szállításkor nem sérült-e és hogy hiánytalan-e. A beépítés után már nem fogadjuk el reklamációt.

D Sicherheitshinweis:
Einscheiben-Sicherheitsgläser nie nachträglich bearbeiten. Glaskanten sind immer zu schützen. Beim Abstellen der Scheiben immer eine weiche Unterlage verwenden.

GB Safety information:
Single-pane, safety glass panels must not be reworked in any way following supply. Protect the edges of the panes and always set them down on a padded surface.

F Remarques concernant la sécurité:
Vous ne devez en aucune façon tenter de retailer les vitrages en verre sécurité. Toujours protéger les bords en verre. Toujours déposer les vitres sur un support doux.

I Cenzo sulla sicurezza:
Non è lecito eseguire lavorazioni successive sui vetri di sicurezza a lastra singola. Proteggere sempre i bordi del cristallo. Posare il cristallo sempre su un basamento morbido.

E Reglamento de seguridad:
Una vez instalados los vidrios de seguridad no se deben someter a manipulación poste rior. Proteger siempre los bordes de los vidrios. Deposite los vidrios siempre sobre una base blanda.

NL Veiligheidsvoorschrift:
Gehard veiligheidsglas mag niet achteraf worden bewerkt. De zijkanten van glasplaten moeten altijd van een bescherming worden voorzien. Gebruik bij het neerzetten van de ruiten altijd een zachte ondergrond.

GR Οδηγία ασφαλείας:
Τα τζάμια ενός υαλοπίνακα ασφαλείας απαγορεύεται να υφίστανται εκ των υστέρων επεξεργασία. Τα γυάλινα άκρα θα πρέπει πάντοτε να προστατεύονται. Κατά την απόθεση των δίσκων να χρησιμοποιείται πάντοτε ένα μαλακό υπόβαθρο.

RUS Указание по безопасности:
Монолитное безопасное стекло запрещается обрабатывать дополнительно. Избегайте повреждения кромок стекла. Отставляя стекла в сторону, обязательно используйте мягкую подкладку.

DK Sikkerhedsoplysning:
Der må ikke foretages ændringer sikkerhedsglas (enkeltrude). Glaskanter skal altid beskyttes. Under arbejdet med glasvæggen, bør et blødt underlag benyttes.

CZ Bezpečnostní pokyny:
Jednotlivé tabule bezpečnostního skla nesmí být dodatečně opracovávány. Chraňte hrany skla. Při pokládání skleněných částí používejte vždy měkké podložky.

PL Wskazówki bezpieczeństwa:
Jednowarstwowych szyb bezpiecznych nie należy poddawać dalszej obróbce. Zabezpieczać krawędzie szkła. Podczas zestawiania szyb należy zawsze stosować miękkie podłoże.

S Säkerhetsupplysning:
Säkerhetsglas med ett glas får inte bearbetas ytterligare efteråt. Glaskanter ska alltid skyddas. Använd alltid ett mjukt underlägg när ni sätter ner skivorna.

P Indicação de segurança:
Os vidros de segurança não devem ser trabalhados ulteriormente. As arestas do vidro sempre devem ser protegidas. Favor colocar o vidro sobre uma superfície macia para evitar danos.

H Biztonsági tudnivalók:
Az egy rétegű biztonsági üvegből készült ajtókat nem szabad utólag megmunkálni. A sérülésektől különösen az üveg éleit óvjuk. Az üvegtáblát mindig valamilyen lágy anyagra állítsuk.

